

MUSTAFA YONTAR A.Ş.



KPM 36

CONCRETE BLOCKMAKING MACHINE

MUSTAFA YONTAR A.Ş.



Mustafa Yontar A.Ş., as cumulatively boosted by its half-century business experience, continues its activities devoted to the manufacture of various building machinery.

Its corporate activity in the sector has preliminarily been initiated on, in order, building elevators, slag breaking machinery, concrete mixers and briquette machinery and subsequently concentrated on the production of the prefabricated concrete components manufacturing machinery.

Our company, currently continuing its activities in its modern factory and facilities built over a closed area of 32.000 m² located in the locality of Istanbul province-Büyükcemece county-Hadımköy tollgate, has a strong competitive standing in the marketplace



Primary products under our scope of manufacturing are; Full automatically or manually operated blockmaking machines of various types and capacities, every sort of concrete paving stone, briquette, asmolene and kerbstone moulds;

Concrete pipe moulds and machines of several types and capacities, employed in the manufacture pipes with diameter and length ranging from 150 mm to 3600 and 500 mm to 4000 m respectively;

Concrete stacks, stack bases, bifurcated pipe and knee machines and required concrete mixers, elevating conveyors, concrete feeding bunkers, aerial mortar handling buckets and every sort of lifting cranes dedicated to the full-capacity operation of all of our machinery under our scope of manufacture. With our experienced team and qualified personnel, we are committed to bringing high class, rapid and cost-effective solutions to the requirements of our customers.

Your contacting with us before giving your final decision on the fulfilment of your requirements in the sector will highly be appreciated.

Yours faithfully
Mustafa YONTAR
Chairman of the Board

KPM 36

FULLY AUTOMATIC

CONCRETE BLOCKMAKING MACHINE



- * KPM 36 FULLY AUTOMATIC Concrete Blockmaking Machine is a system capable of serially manufacturing interlocking or not-interlocking paving stones.
- * System operation is programmed via a PLC microprocessor computer.
- * System is capable of stamping 8 lines of stone piles each with a height of 80 mm on a wooden palette.



MUSTAFA YONTAR A.Ş.

KPM 36 FULLY AUTOMATIC multi-layer concrete paving stone manufacturing machine.

Upon conducting a comparison, taking the machine cost, production capacity and production cost into consideration, "KMP 36 FULL AUTOMATIC", capable of manufacturing 8 lines of product on a single palette, will certainly be more attractive to the pavement manufacturers.

* Forms an 8 m² stones pile in a very short period of time.

* Regardless of the stone type, stamps stone in adequate capacity to form a 1m² area per each stamping.

* In case height of stone stamped goes down under 80 mm, number of lines of piles goes up.

KPM 36 FULLY AUTOMATIC CONCRETE BLOCKMAKING MACHINE

KPM 36 FULLY AUTOMATIC Blockmaking Machine		technical specifications
Type of Operation	FULLY AUTOMATIC	
Machine Dimensions	max. lenght	14000 mm
	max. width (*)	6750 mm
	max. height (**)	4450mm
Number of Bottom Vibrators	2 pcs.	
Number of Top Vibrators	4 pcs.	
Hydraulic Tank Capacity	1400 lt.	
Number of Hydraulic Pumps	(4+1) 5 pcs.	
Total Electrical Motor Power	82 kW	
Height of Stamped Product (max. / min.)	300 mm / 50 mm	
Production Palette Dimensions	1150 mm x 1300 x 130mm	
Max. Height of Stamped Pile	640 mm (8 ÷ 10 lines)	
Cycle Time	30 ÷ 35 sec.	
Mortar Bunker Capacity	2 x 1.8 m ³	
Hydraulic Pumping Flow Rate	148 lt. / min.	
Average Hydraulic Pressure	180 bar.	

(*) - Width of the control panel is included in the dimensions.

(**) - The projecting part of the hydraulic piston is included in the machine height dimensions.

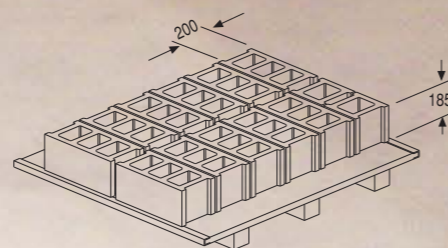
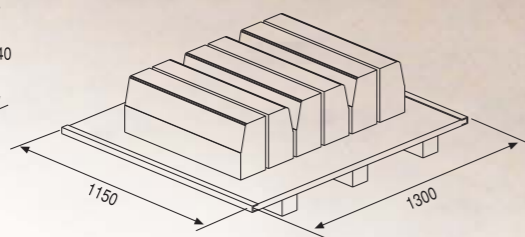
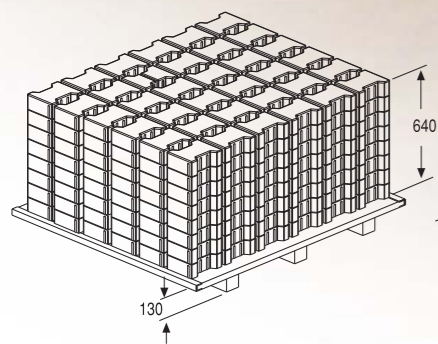

MUSTAFA YONTAR A.Ş.

KPM 36 FULLY AUTOMATIC CONCRETE BLOCKMAKING MACHINE



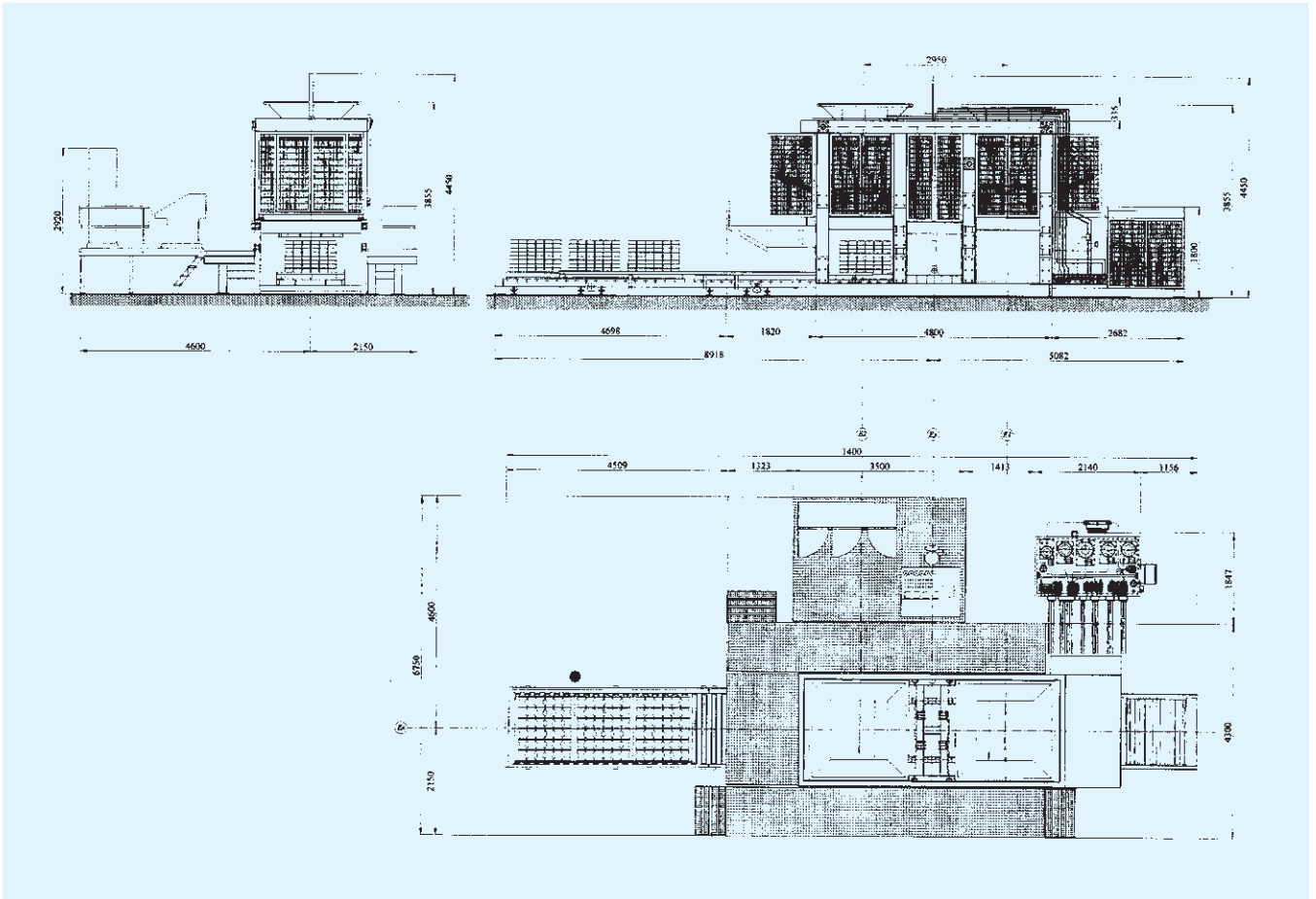
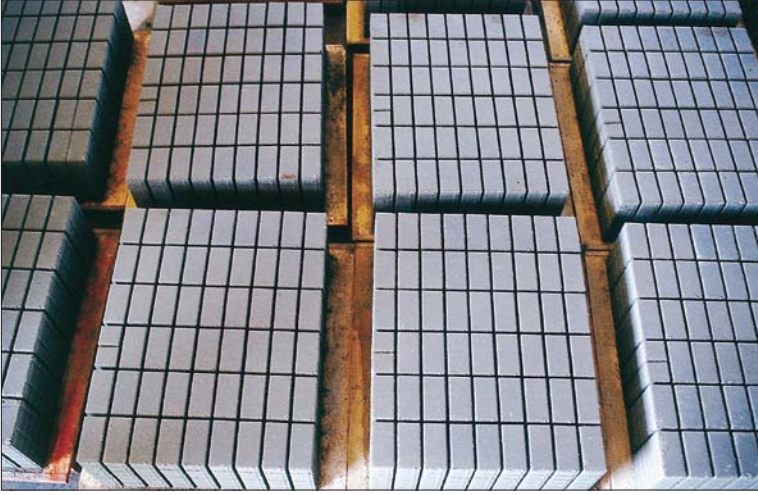

MY MUSTAFA YONTAR
İNŞAAT MAKİNALARI ve KALIP SAN.TİC.A.Ş.

Orhan Gazi Mahallesi, Sanayi Caddesi No:11 34538 Esenyurt / İSTANBUL-TURKEY
(Tem Otoyolu, Hadımköy Gişeleri Mevkii)

Tel : +90 212 623 21 21 Pbx Fax : +90 212 623 21 22 Fax : +90 212 623 21 23
e-mail : yontar@mustafayontar.com.tr web : www.mustafayontar.com.tr

